

Harpe, the sound of *light*

design Christian Lava
terzani.com

TERZANI



Name
Harpe
single pendant

Materials
metal



Finishes | Code

-  matte pearl |
grey fabric cord
OW011SE8B5KK
-  matte black nickel |
grey fabric cord
OW011SE8B6KK
-  matte red gold |
champagne fabric cord
OW011SE8B8KK

Body

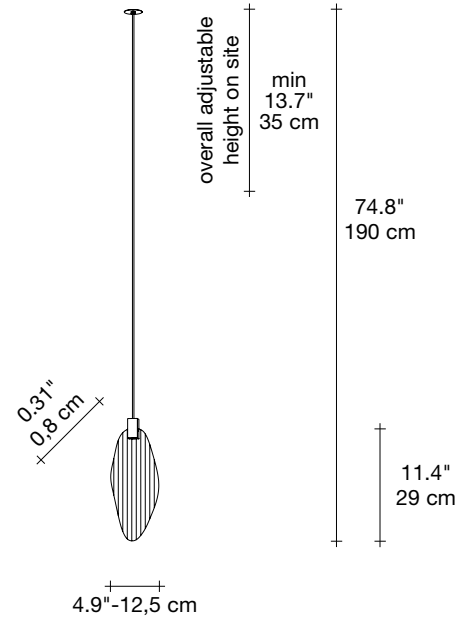

Light source
700mA

-  Integrated LED
2,1W 237 lm 3000K
or optional 223 lm 2700K



dimnable drivers available

-  IGBT
TRIAC
1-10V
0/1-10V
PUSH
DALI

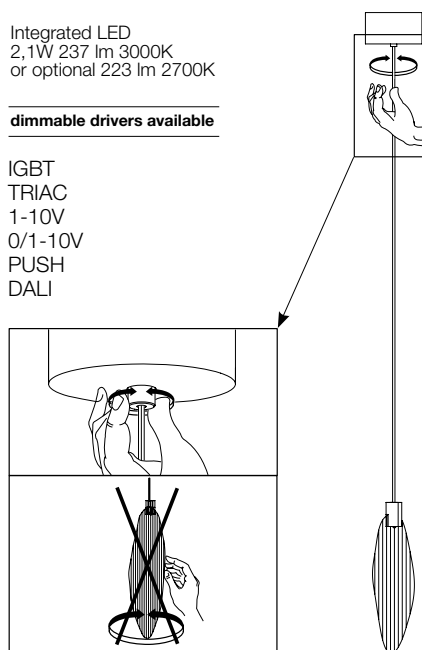
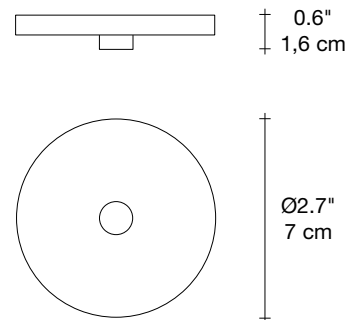
Disc | white



The new Harpe collection comes from the childhood memory of its designer, Christian Lava. Like most children, he would look up into the sky and visualize shapes in the clouds as they passed by. His active imagination would run wild with the fantastic things that emerged. One day, Christian looked up into the sky only to see a gray, leaden blanket of clouds. However, against this blank canvas, a break in the sky appeared, and bright sunlight came streaming down in rays reminiscent of a harp. It's the memory of this divine instrument that inspired our latest pendant, Harpe. Made of metal, Harpe is available in three different shapes and sizes, and can be assembled in infinite combinations. Design Christian Lava.

-  0.88 lbs
0,4 kg
-  1.54 lbs
0,7 kg
-  12.6" x 9.5" x 6.7"
32 x 24 x 17 cm

Harpe, the sound of *light*

design Christian Lava
terzani.com

TERZANI



Name
Harpe
single pendant

Materials
metal



Finishes | Code

-  matte pearl |
grey fabric cord
OW011SE8B5T
-  matte black nickel |
grey fabric cord
OW011SE8B6T
-  matte red gold |
champagne fabric cord
OW011SE8B8T

Body

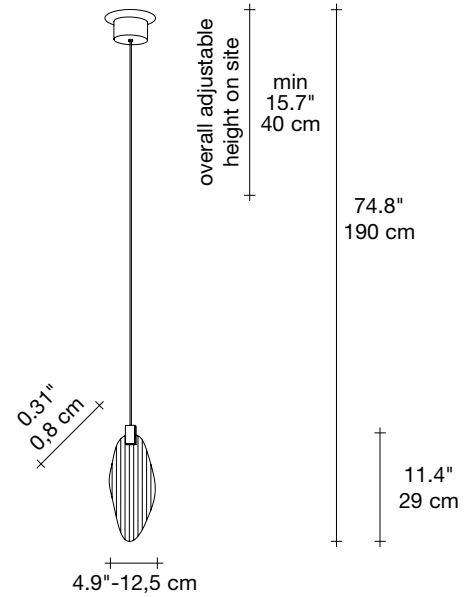

Light source

700mA

-  Integrated LED
2,1W 237 lm 3000K
or optional 223 lm 2700K

dimmmable drivers available

-  IGBT
TRIAC

Canopy | white

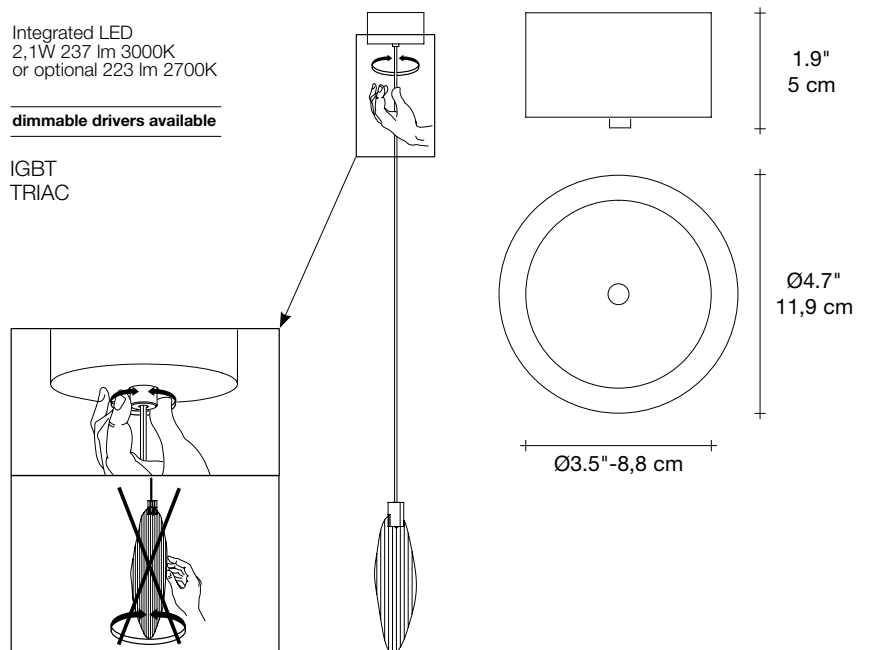

The new Harpe collection comes from the childhood memory of its designer, Christian Lava. Like most children, he would look up into the sky and visualize shapes in the clouds as they passed by. His active imagination would run wild with the fantastic things that emerged. One day, Christian looked up into the sky only to see a gray, leaden blanket of clouds. However, against this blank canvas, a break in the sky appeared, and bright sunlight came streaming down in rays reminiscent of a harp. It's the memory of this divine instrument that inspired our latest pendant, Harpe. Made of metal, Harpe is available in three different shapes and sizes, and can be assembled in infinite combinations. Design Christian Lava.

Harpe, the sound of *light*

design Christian Lava
terzani.com

TERZANI



Name
Harpe
single pendant

Materials
metal



Finishes | Code

-  matte pearl |
grey fabric cord
OW012SE8B5KK
-  matte black nickel |
grey fabric cord
OW012SE8B6KK
-  matte red gold |
champagne fabric cord
OW012SE8B8KK

Body

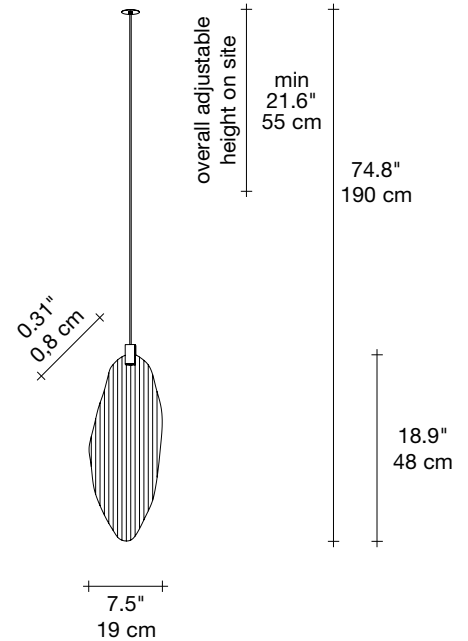

Light source
700mA

-  Integrated LED
2,1W 237 lm 3000K
or optional 223 lm 2700K

dimmmable drivers available

-  IGBT
TRIAC
1-10V
0/1-10V
PUSH
DALI

Disc | white

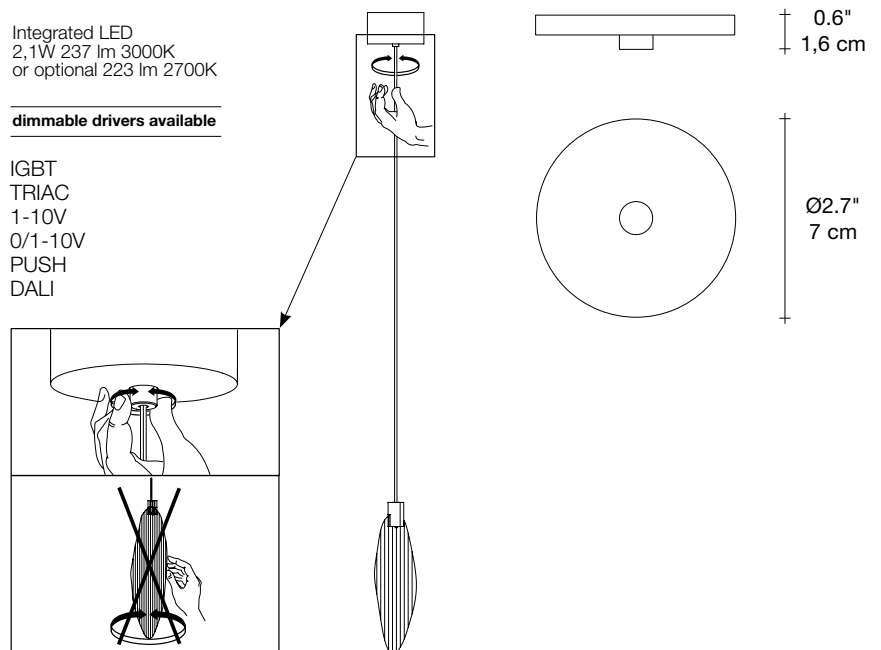

The new Harpe collection comes from the childhood memory of its designer, Christian Lava. Like most children, he would look up into the sky and visualize shapes in the clouds as they passed by. His active imagination would run wild with the fantastic things that emerged. One day, Christian looked up into the sky only to see a gray, leaden blanket of clouds. However, against this blank canvas, a break in the sky appeared, and bright sunlight came streaming down in rays reminiscent of a harp. It's the memory of this divine instrument that inspired our latest pendant, Harpe. Made of metal, Harpe is available in three different shapes and sizes, and can be assembled in infinite combinations. Design Christian Lava.

 3 lbs
1,4 kg

 4 lbs
1,8 kg

 23.6" × 11.8" × 6.3"
60 × 30 × 16 cm

Harpe, the sound of *light*

design Christian Lava
terzani.com

TERZANI



Name
Harpe
single pendant

Materials
metal





Finishes | Code

-  matte pearl |
grey fabric cord
OW012SE8B5T
-  matte black nickel |
grey fabric cord
OW012SE8B6T
-  matte red gold |
champagne fabric cord
OW012SE8B8T

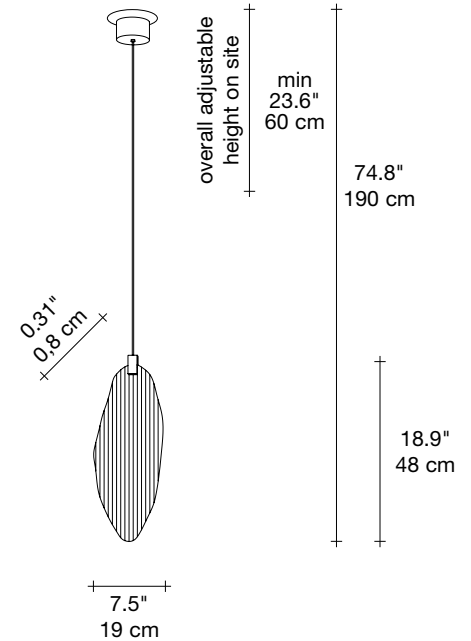
Body





Light source
120V ~ 50/60Hz

-  Integrated LED
2,1W 237 lm 3000K
or optional 223 lm 2700K
- dimmmable drivers available
-  IGBT
TRIAC

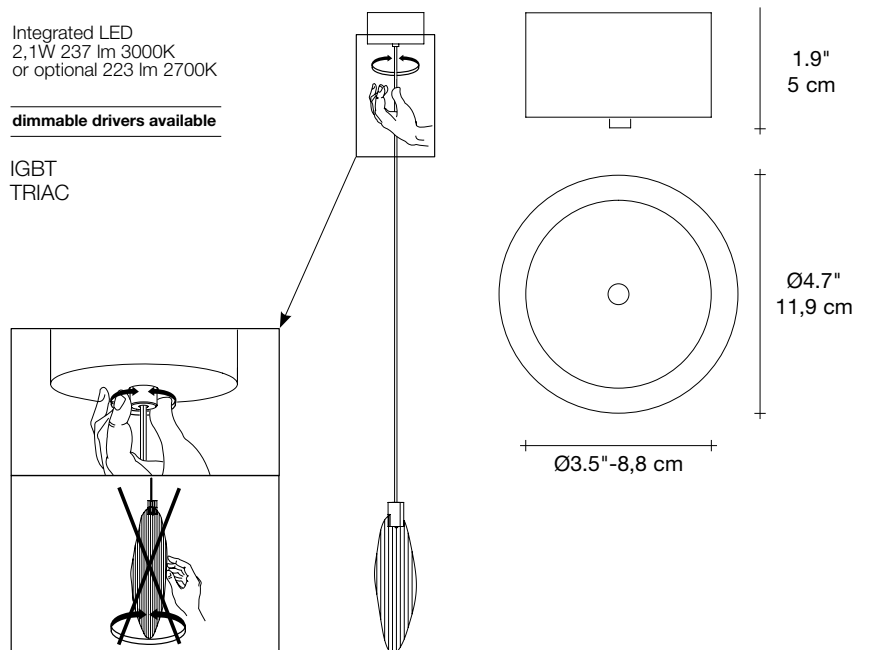
Canopy | white



The new Harpe collection comes from the childhood memory of its designer, Christian Lava. Like most children, he would look up into the sky and visualize shapes in the clouds as they passed by. His active imagination would run wild with the fantastic things that emerged. One day, Christian looked up into the sky only to see a gray, leaden blanket of clouds. However, against this blank canvas, a break in the sky appeared, and bright sunlight came streaming down in rays reminiscent of a harp. It's the memory of this divine instrument that inspired our latest pendant, Harpe. Made of metal, Harpe is available in three different shapes and sizes, and can be assembled in infinite combinations. Design Christian Lava.

-  3.3 lbs
1,5 kg
-  4.4 lbs
2 kg
-  23.6" x 11.8" x 6.3"
60 x 30 x 16 cm

Harpe, the sound of *light*

design Christian Lava
terzani.com

TERZANI



Name
Harpe
single pendant

Materials
metal



Finishes | Code

-  matte pearl |
grey fabric cord
OW013SE8B5KK
-  matte black nickel |
grey fabric cord
OW013SE8B6KK
-  matte red gold |
champagne fabric cord
OW013SE8B8KK

Body

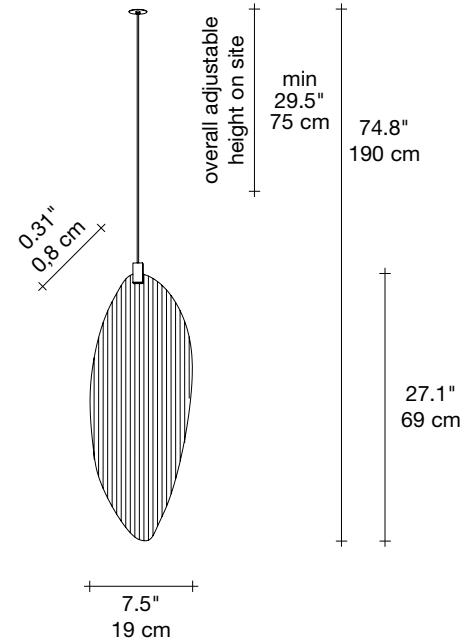

Light source

700mA

-  Integrated LED
2,1W 237 lm 3000K
or optional 223 lm 2700K



dimnable drivers available

-  IGBT
TRIAC
1-10V
0/1-10V
PUSH
DALI

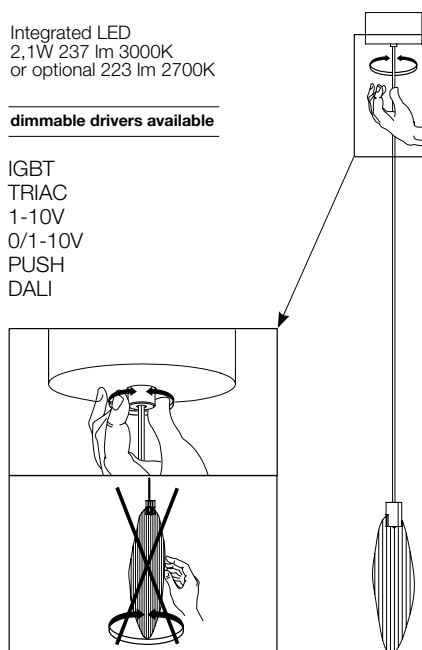
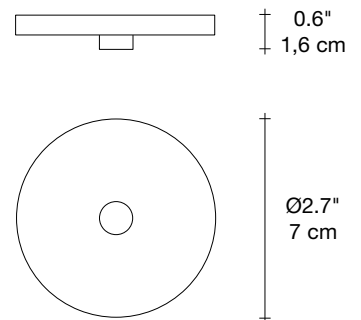
Disc | white



The new Harpe collection comes from the childhood memory of its designer, Christian Lava. Like most children, he would look up into the sky and visualize shapes in the clouds as they passed by. His active imagination would run wild with the fantastic things that emerged. One day, Christian looked up into the sky only to see a gray, leaden blanket of clouds. However, against this blank canvas, a break in the sky appeared, and bright sunlight came streaming down in rays reminiscent of a harp. It's the memory of this divine instrument that inspired our latest pendant, Harpe. Made of metal, Harpe is available in three different shapes and sizes, and can be assembled in infinite combinations. Design Christian Lava.

-  4.9 lbs
2,2 kg
-  6 lbs
2,7 kg
-  33.3" x 13.8" x 10.5"
84,5 x 35 x 26,5 cm

Harpe, the sound of *light*

design Christian Lava
terzani.com

TERZANI



Name
Harpe
single pendant

Materials
metal





Finishes | Code

-  matte pearl |
grey fabric cord
OW013SE8B5T
-  matte black nickel |
grey fabric cord
OW013SE8B6T
-  matte red gold |
champagne fabric cord
OW013SE8B8T

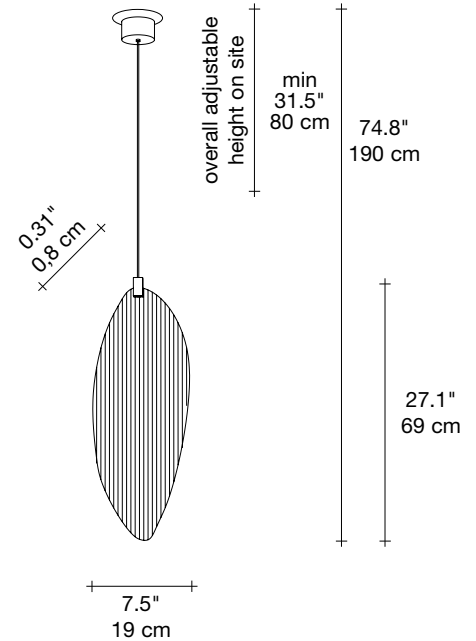
Body





Light source
120V ~ 50/60Hz

-  Integrated LED
2,1W 237 lm 3000K
or optional 223 lm 2700K
- dimming drivers available
-  IGBT
TRIAC

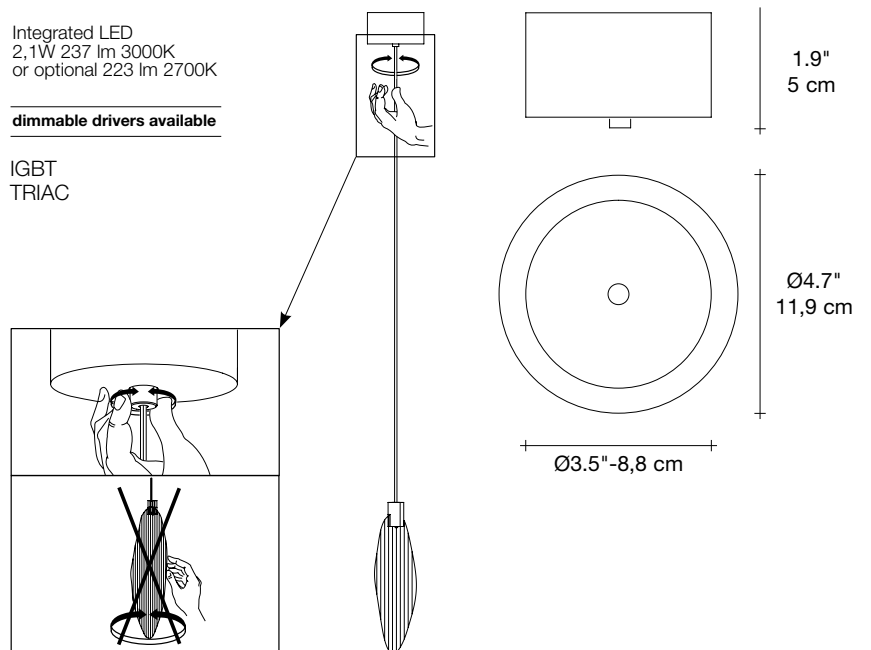
Canopy | white



The new Harpe collection comes from the childhood memory of its designer, Christian Lava. Like most children, he would look up into the sky and visualize shapes in the clouds as they passed by. His active imagination would run wild with the fantastic things that emerged. One day, Christian looked up into the sky only to see a gray, leaden blanket of clouds. However, against this blank canvas, a break in the sky appeared, and bright sunlight came streaming down in rays reminiscent of a harp. It's the memory of this divine instrument that inspired our latest pendant, Harpe. Made of metal, Harpe is available in three different shapes and sizes, and can be assembled in infinite combinations. Design Christian Lava.

-  5 lbs
2,3 kg
-  6.2 lbs
2,8 kg
-  30.3" x 13.8" x 10.4"
77 x 35 x 26,5 cm

Harpe, the sound of *light*

design Christian Lava
terzani.com

TERZANI



Name
Harpe
2 light pendant

Materials
metal



Finishes | Code

-  matte pearl |
grey fabric cord
OW024SE8B5T
-  matte black nickel |
grey fabric cord
OW024SE8B6T
-  matte red gold |
champagne fabric cord
OW024SE8B8T

Body

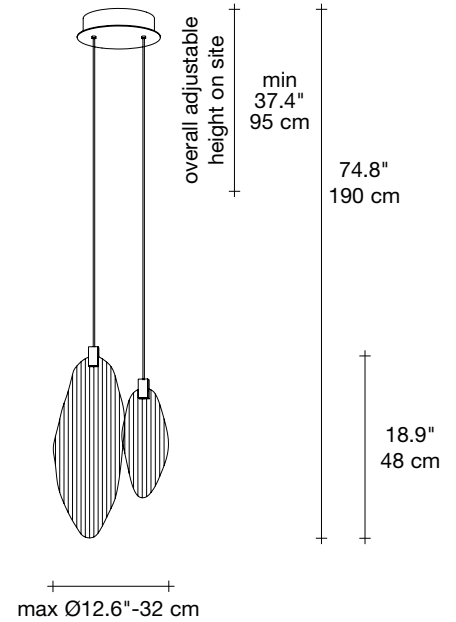

Light source
120V ~ 50/60Hz

-  Integrated LED
2 x 2,1W 474 lm 3000K
or optional 446 lm 2700K



dimable drivers available

-  IGBT
TRIAC

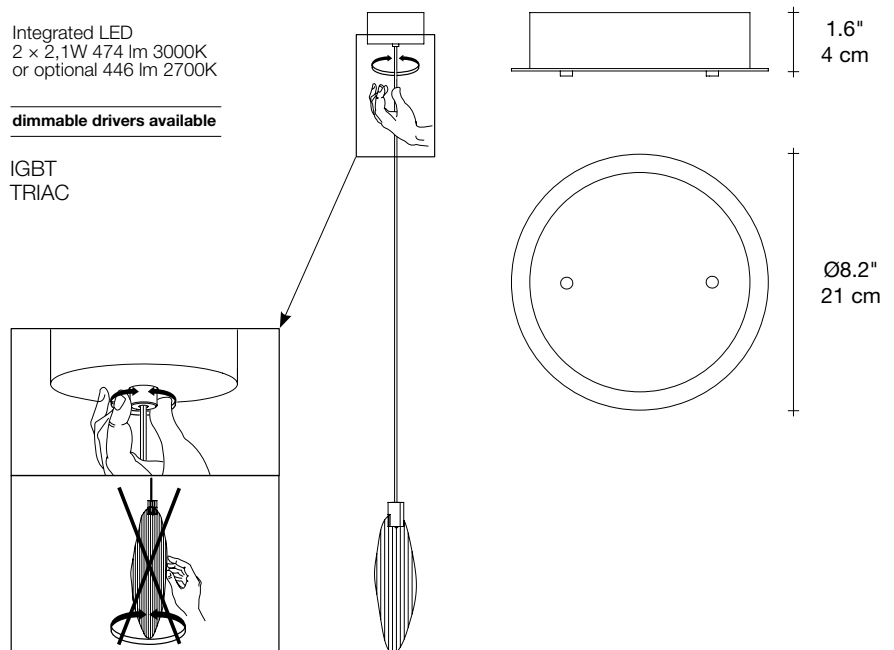
Canopy | white



The new Harpe collection comes from the childhood memory of its designer, Christian Lava. Like most children, he would look up into the sky and visualize shapes in the clouds as they passed by. His active imagination would run wild with the fantastic things that emerged. One day, Christian looked up into the sky only to see a gray, leaden blanket of clouds. However, against this blank canvas, a break in the sky appeared, and bright sunlight came streaming down in rays reminiscent of a harp. It's the memory of this divine instrument that inspired our latest pendant, Harpe. Made of metal, Harpe is available in three different shapes and sizes, and can be assembled in infinite combinations. Design Christian Lava.

-  8.4 lbs
3,8 kg
-  9.9 lbs
4,5 kg
-  25.6" x 10.6" x 9.7"
65 x 27 x 24,5 cm

Harpe, the sound of *light*

design Christian Lava
terzani.com

TERZANI



Name
Harpe
2 light pendant

Materials
metal



Finishes | Code

-  matte pearl |
grey fabric cord
OW025SE8B5T
-  matte black nickel |
grey fabric cord
OW025SE8B6T
-  matte red gold |
champagne fabric cord
OW025SE8B8T

Body

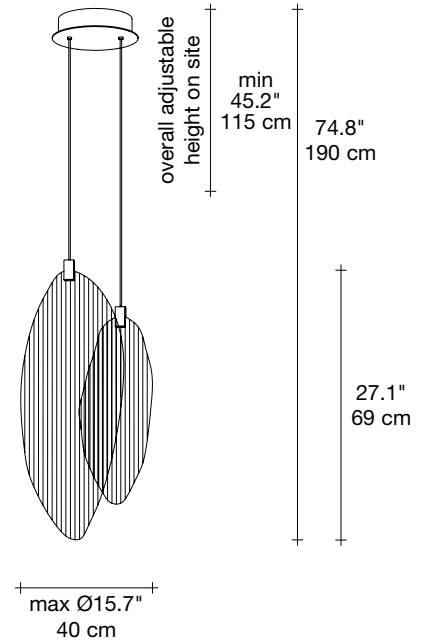

Light source
120V ~ 50/60Hz

-  Integrated LED
2 x 2,1W 474 lm 3000K
or optional 446 lm 2700K



dimnable drivers available

-  IGBT
TRIAC

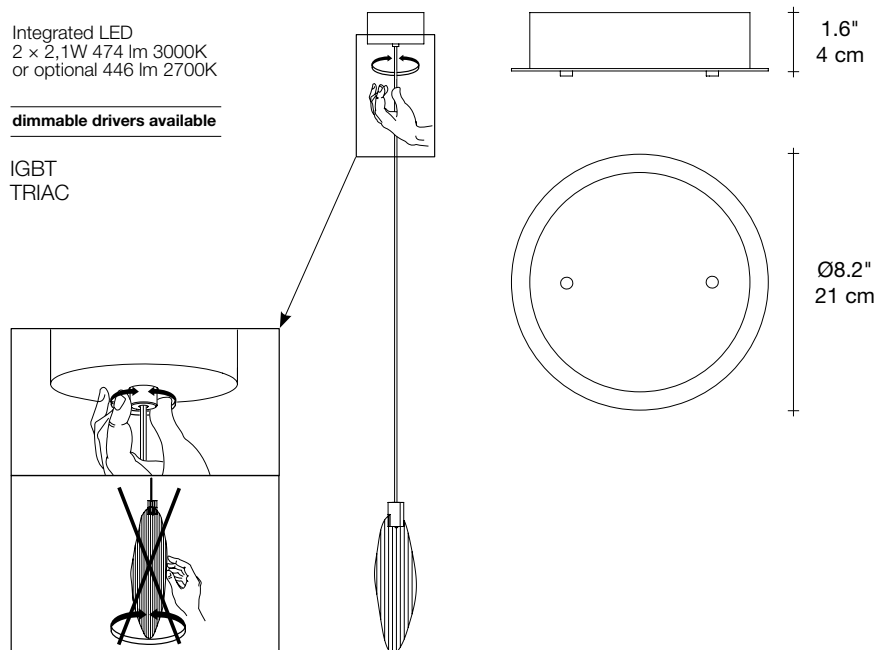
Canopy | white



The new Harpe collection comes from the childhood memory of its designer, Christian Lava. Like most children, he would look up into the sky and visualize shapes in the clouds as they passed by. His active imagination would run wild with the fantastic things that emerged. One day, Christian looked up into the sky only to see a gray, leaden blanket of clouds. However, against this blank canvas, a break in the sky appeared, and bright sunlight came streaming down in rays reminiscent of a harp. It's the memory of this divine instrument that inspired our latest pendant, Harpe. Made of metal, Harpe is available in three different shapes and sizes, and can be assembled in infinite combinations. Design Christian Lava.

-  12.3 lbs
5,6 kg
-  13.9 lbs
6,3 kg
-  30.3" x 13.8" x 10.4"
77 x 35 x 26,5 cm

Harpe, the sound of *light*

design Christian Lava
terzani.com

TERZANI



Name
Harpe
3 light pendant

Materials
metal



Finishes | Code

-  matte pearl |
grey fabric cord
OW034SE8B5T
-  matte black nickel |
grey fabric cord
OW034SE8B6T
-  matte red gold |
champagne fabric cord
OW034SE8B8T

Body

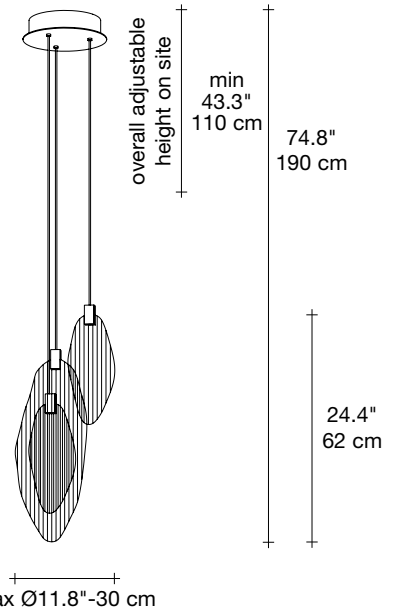

Light source
120V ~ 50/60Hz

-  Integrated LED
3 x 2,1W 711 lm 3000K
or optional 669 lm 2700K

dimnable drivers available

-  IGBT
TRIAC

Canopy | white

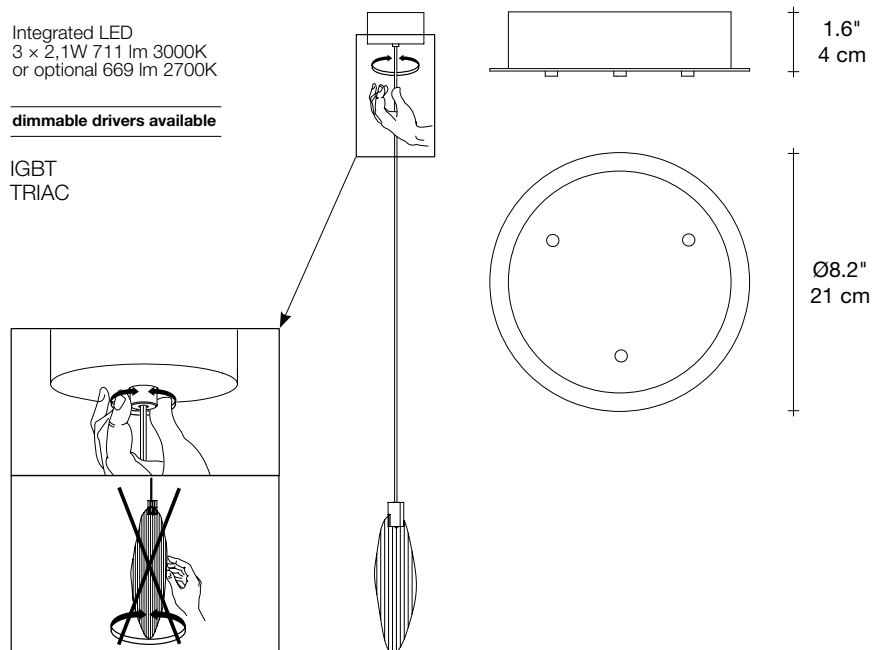

The new Harpe collection comes from the childhood memory of its designer, Christian Lava. Like most children, he would look up into the sky and visualize shapes in the clouds as they passed by. His active imagination would run wild with the fantastic things that emerged. One day, Christian looked up into the sky only to see a gray, leaden blanket of clouds. However, against this blank canvas, a break in the sky appeared, and bright sunlight came streaming down in rays reminiscent of a harp. It's the memory of this divine instrument that inspired our latest pendant, Harpe. Made of metal, Harpe is available in three different shapes and sizes, and can be assembled in infinite combinations. Design Christian Lava.

Harpe, the sound of *light*

design Christian Lava
terzani.com

TERZANI



Name
Harpe
3 light pendant

Materials
metal



Finishes | Code

-  matte pearl |
grey fabric cord
OW037SE8B5T
-  matte black nickel |
grey fabric cord
OW037SE8B6T
-  matte red gold |
champagne fabric cord
OW037SE8B8T

Body

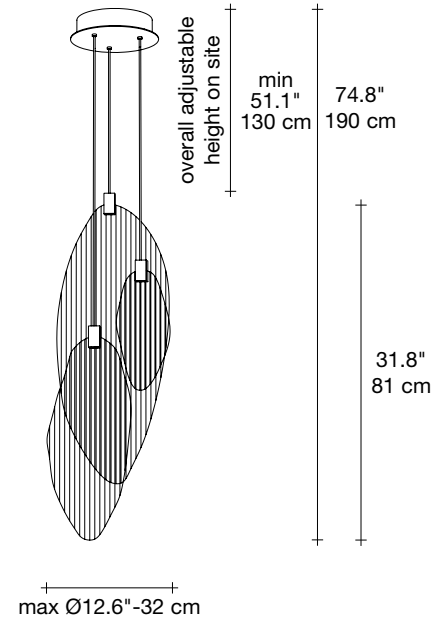

Light source
120V ~ 50/60Hz

-  Integrated LED
3 x 2,1W 711 lm 3000K
or optional 669 lm 2700K



dimable drivers available

-  IGBT
TRIAC

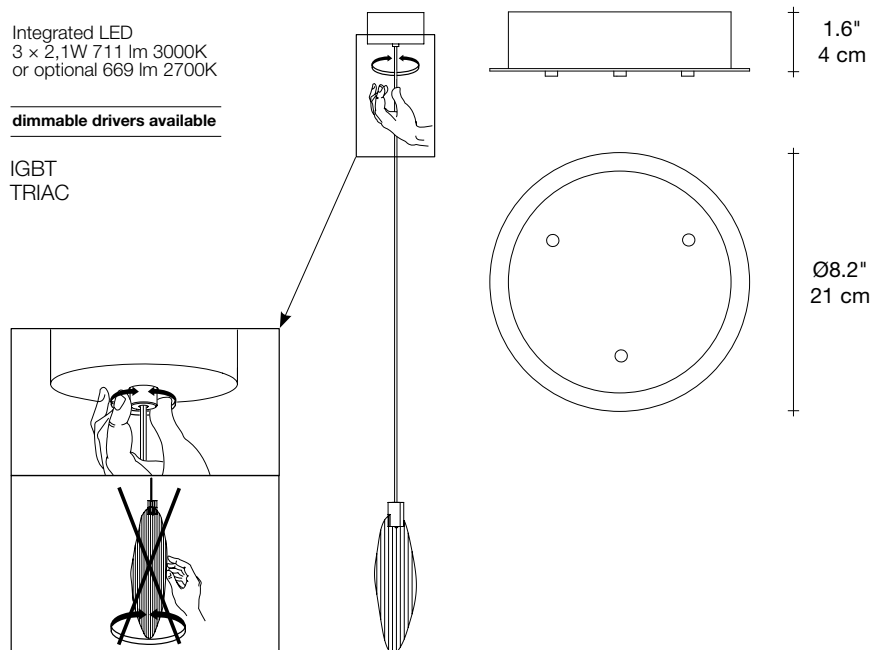
Canopy | white



The new Harpe collection comes from the childhood memory of its designer, Christian Lava. Like most children, he would look up into the sky and visualize shapes in the clouds as they passed by. His active imagination would run wild with the fantastic things that emerged. One day, Christian looked up into the sky only to see a gray, leaden blanket of clouds. However, against this blank canvas, a break in the sky appeared, and bright sunlight came streaming down in rays reminiscent of a harp. It's the memory of this divine instrument that inspired our latest pendant, Harpe. Made of metal, Harpe is available in three different shapes and sizes, and can be assembled in infinite combinations. Design Christian Lava.

-  13.2 lbs
6 kg
-  14.3 lbs
6,5 kg
-  30.3" x 13.8" x 10.4"
77 x 35 x 26,5 cm