

I Lucci Argentati, school of *light*.

design Dodo Arslan
terzani.com

TERZANI



Name
I Lucci Argentati
small linear chandelier

Materials
metal



Finishes | Code

-  white polished
ON82SM2C8L
-  brushed nickel plated
ON82SH4C8L
-  brushed gold plated
ON82SL9C8L

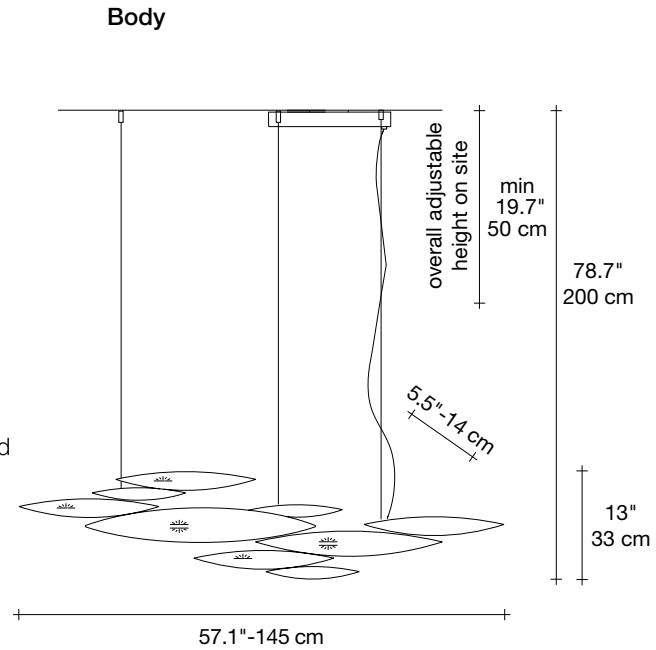

Light source

120V ~ 50/60Hz



Built in Replaceable LED Module
7 x 4.5W 4632 lm CRI 90 3000K
or optional 4200 lm 2700K

dimnable options



1-10V
PWM
10-100kΩ

Canopy

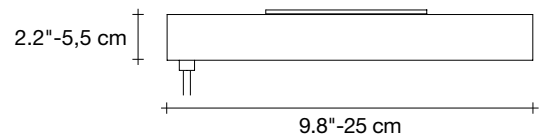
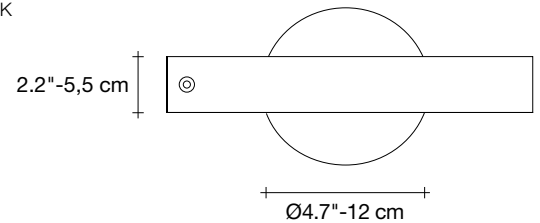

I Lucci Argentati draws from nature to create a whimsical, yet modern light. Recalling a school of fish darting through freshwater, it creates a mesmerizing luminescence. Sets of sleek elements combine to form a stunning pendant with thin incisions along the bottom, creating an understated, tranquil beauty. Thanks to its modular system, I Lucci Argentati is customizable and can be combined in many different configurations: from small to extra large, and finished either in brushed nickel, brushed gold, or white. Design Dodo Arslan.

I Lucci Argentati, school of *light*.

design Dodo Arslan
terzani.com

TERZANI



Name
I Lucci Argentati
medium linear chandelier

Materials
metal



Finishes | Code

-  white polished
ON83SM2C8L
-  brushed nickel plated
ON83SH4C8L
-  brushed gold plated
ON83SL9C8L

Body

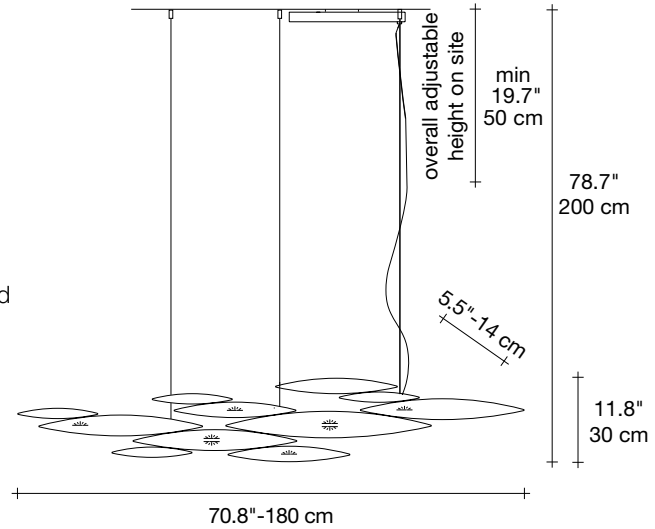

Light source
120V ~ 50/60Hz

 Built in Replaceable LED Module
8 x 4.5W 5294 lm CRI 90 3000K
or optional 4800 lm 2700K

dimnable options

-  1-10V
PWM
10-100kΩ

Canopy

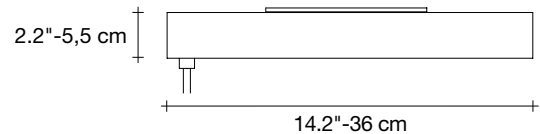
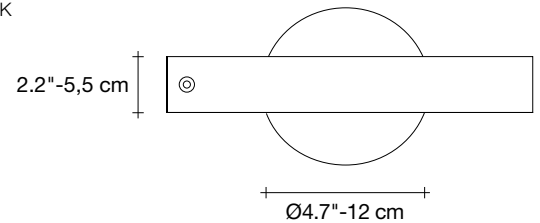

I Lucci Argentati draws from nature to create a whimsical, yet modern light. Recalling a school of fish darting through freshwater, it creates a mesmerizing luminescence. Sets of sleek elements combine to form a stunning pendant with thin incisions along the bottom, creating an understated, tranquil beauty. Thanks to its modular system, I Lucci Argentati is customizable and can be combined in many different configurations: from small to extra large, and finished either in brushed nickel, brushed gold, or white. Design Dodo Arslan.

I Lucci Argentati, school of *light*.

design Dodo Arslan
terzani.com

TERZANI



Name
I Lucci Argentati
large linear chandelier

Materials
metal



Finishes | Code

-  white polished
ON81SM2C8L
-  brushed nickel plated
ON81SH4C8L
-  brushed gold plated
ON81SL9C8L

Body

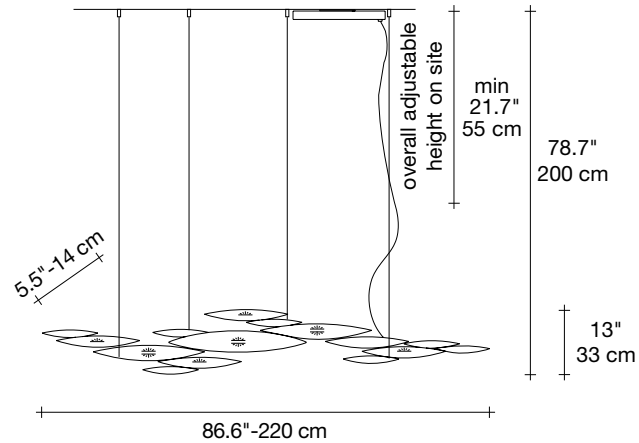

Light source
120V ~ 50/60Hz

 Built in Replaceable LED Module
10 x 4.5W 6617 lm CRI 90 3000K
or optional 6000 lm 2700K



dimmmable options

-  1-10V
PWM
10-100kΩ

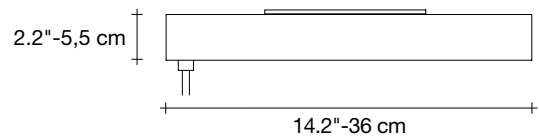
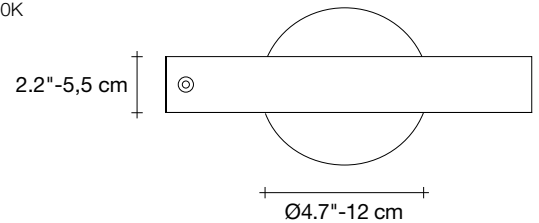
Canopy



I Lucci Argentati draws from nature to create a whimsical, yet modern light. Recalling a school of fish darting through freshwater, it creates a mesmerizing luminescence. Sets of sleek elements combine to form a stunning pendant with thin incisions along the bottom, creating an understated, tranquil beauty. Thanks to its modular system, I Lucci Argentati is customizable and can be combined in many different configurations: from small to extra large, and finished either in brushed nickel, brushed gold, or white. Design Dodo Arslan.

-  19.8 lbs
9 kg
-  39.7 lbs
18 kg
-  94.9" x 18.1" x 8.7"
241 x 46 x 22 cm

I Lucci Argentati, school of *light*.

design Dodo Arslan
terzani.com

TERZANI



Name
I Lucci Argentati
xlarge linear chandelier

Materials
metal



Finishes | Code

-  white polished
ON80SM2C8L
-  brushed nickel plated
ON80SH4C8L
-  brushed gold plated
ON80SL9C8L

Body

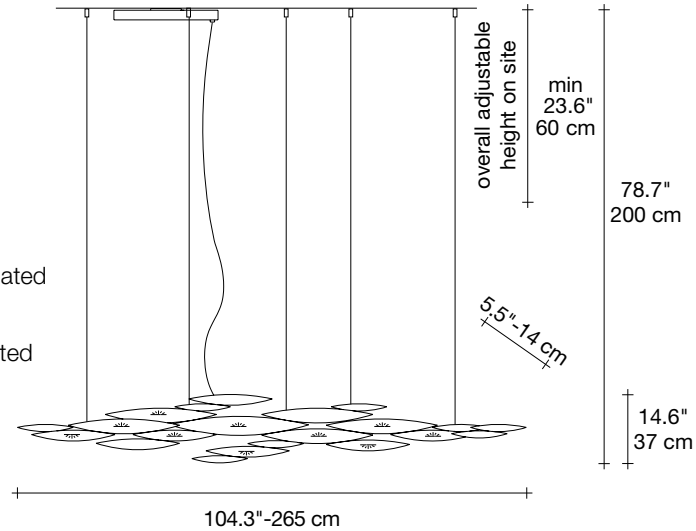

Light source
120V ~ 50/60Hz



Built in Replaceable LED Module
10 x 4.5W 6617 lm CRI 90 3000K
or optional 6000 lm 2700K

dimmmable options

-  1-10V
PWM
10-100kΩ

Canopy

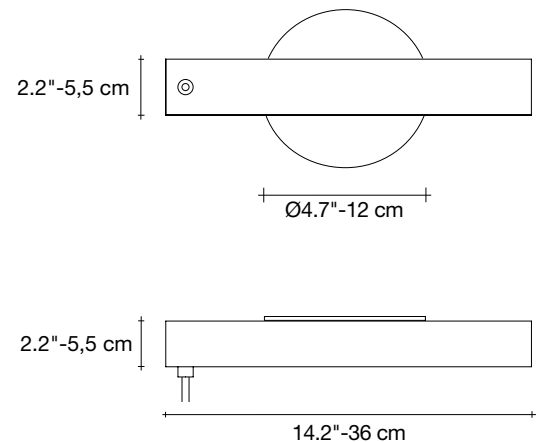

I Lucci Argentati draws from nature to create a whimsical, yet modern light. Recalling a school of fish darting through freshwater, it creates a mesmerizing luminescence. Sets of sleek elements combine to form a stunning pendant with thin incisions along the bottom, creating an understated, tranquil beauty. Thanks to its modular system, I Lucci Argentati is customizable and can be combined in many different configurations: from small to extra large, and finished either in brushed nickel, brushed gold, or white. Design Dodo Arslan.

I Lucci Argentati, school of *light*.

design Dodo Arslan
terzani.com

TERZANI



Name

I Lucci Argentati
wall sconce

Materials

metal



Finishes | Code



white polished
ON85AM2C8LB



brushed nickel plated
ON85AH4C8LB



brushed gold plated
ON85AL9C8LB

Body

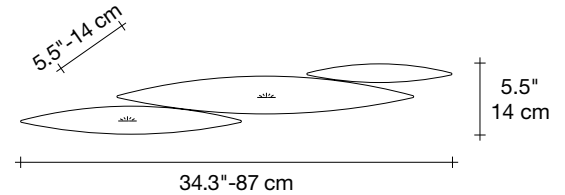

Light source

120V ~ 50/60Hz



Built in Replaceable LED Module
2 x 4.5W 1323 lm CRI 90 3000K
or optional 1200 lm 2700K



not dimmable

Canopy

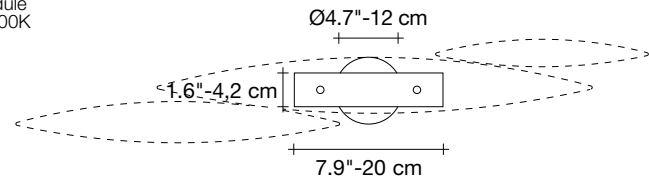

I Lucci Argentati draws from nature to create a whimsical, yet modern light. Recalling a school of fish darting through freshwater, it creates a mesmerizing luminescence. Sets of sleek elements combine to form a stunning pendant with thin incisions along the bottom, creating an understated, tranquil beauty. Thanks to its modular system, I Lucci Argentati is customizable and can be combined in many different configurations: from small to extra large, and finished either in brushed nickel, brushed gold, or white. Design Dodo Arslan.