

Argent, mon bijou.

design Dodo Arslan
terzani.com

TERZANI



Name
Argent, mon bijou
pendant light

Material
stainless steel

CE ENEC CB

Finishes | Code

-  stainless steel
OS01S E8 H9 KK
-  gold
OS01S E8 P7 KK
-  sunset rose
OS01S E8 A8 KK
-  champagne
OS01S E8 Q1 KK

Body

DRIVER NOT INCLUDED

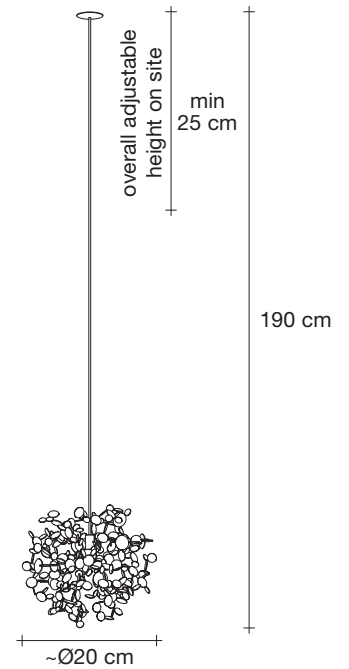

When our Argent collection debuted a decade ago, we knew we had created something special. Working with designer Dodo Arslan, our melding of Italian craftsmanship with contemporary design redefined the industry. Ten years later, we are building upon the success of this original collection with a new chapter: Argent, Mon Bijou.

Again, partnering with Dodo Arslan, we asked ourselves: what have we learned from our evolution as designers and craftsmen? How can we make this new collection as daring, beautiful, and innovative as its predecessor? Our answer is a new series of pendant lights and table lamps that draw inspiration from across design: from the fashion of Paco Rabanne, the work of Verner Panton, the mirrored art of Julio Le Parc, and the natural beauty of the Italian seaside. The result is a lamp reminiscent of a shimmering cloud casting brilliant, ethereal light across the room. Handmade by our craftsmen in stainless steel, each piece is both unique and a modular element of an extremely flexible system. Our goal is to give architects and designers the freedom to express their visions without limits, adapt to any environment, and add a touch of magic. Design Dodo Arslan.

Light source

500mA

-  Built in replaceable led module
1,5W 174 lm 3000K
or optional 1,5W 164 lm 2700K

dimnable drivers available

-  IGBT
TRIAC
1-10V
0/1-10V
PUSH
DALI

Disc | white

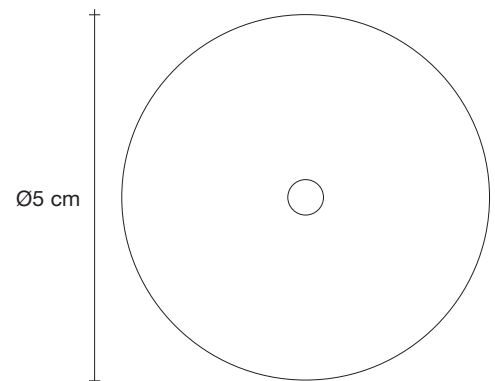

Argent, mon bijou.

design Dodo Arslan
terzani.com

TERZANI



Name





Argent, mon bijou
pendant light

Material

stainless steel



Finishes | Code

-  stainless steel
OS01S E8 H9 T
-  gold
OS01S E8 P7 T
-  sunset rose
OS01S E8 A8 T
-  champagne
OS01S E8 Q1 T

Body

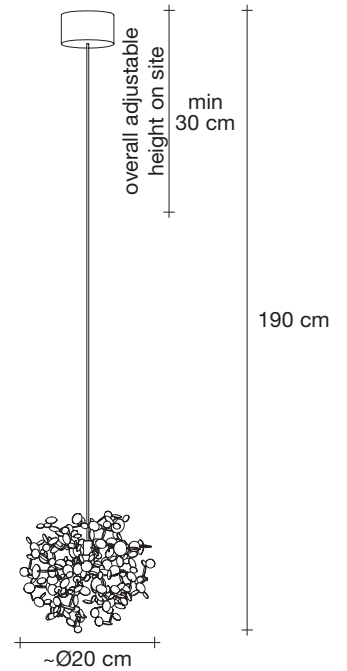

When our Argent collection debuted a decade ago, we knew we had created something special. Working with designer Dodo Arslan, our melding of Italian craftsmanship with contemporary design redefined the industry. Ten years later, we are building upon the success of this original collection with a new chapter: Argent, Mon Bijou.

Again, partnering with Dodo Arslan, we asked ourselves: what have we learned from our evolution as designers and craftsmen? How can we make this new collection as daring, beautiful, and innovative as its predecessor? Our answer is a new series of pendant lights and table lamps that draw inspiration from across design: from the fashion of Paco Rabanne, the work of Verner Panton, the mirrored art of Julio Le Parc, and the natural beauty of the Italian seaside. The result is a lamp reminiscent of a shimmering cloud casting brilliant, ethereal light across the room. Handmade by our craftsmen in stainless steel, each piece is both unique and a modular element of an extremely flexible system. Our goal is to give architects and designers the freedom to express their visions without limits, adapt to any environment, and add a touch of magic. Design Dodo Arslan.

Light source

220-240V ~ 50/60Hz

-  Built in replaceable led module
1,5W 174 lm 3000K
or optional 1,5W 164 lm 2700K

dimmable options

-  IGBT
-  TRIAC

Disc | white

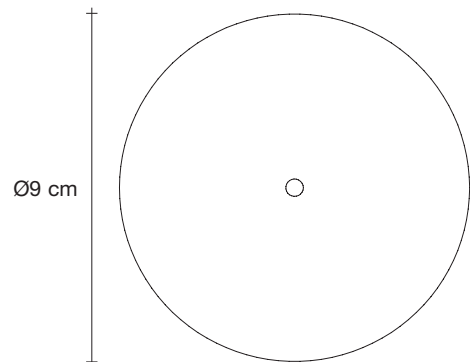

Argent, mon bijou.

design Dodo Arslan
terzani.com

TERZANI



Name





Argent, mon bijou
3 light pendant

Material

stainless steel



Finishes | Code

-  stainless steel
OS03S E8 H9 T
-  gold
OS03S E8 P7 T
-  sunset rose
OS03S E8 A8 T
-  champagne
OS03S E8 Q1 T

Body

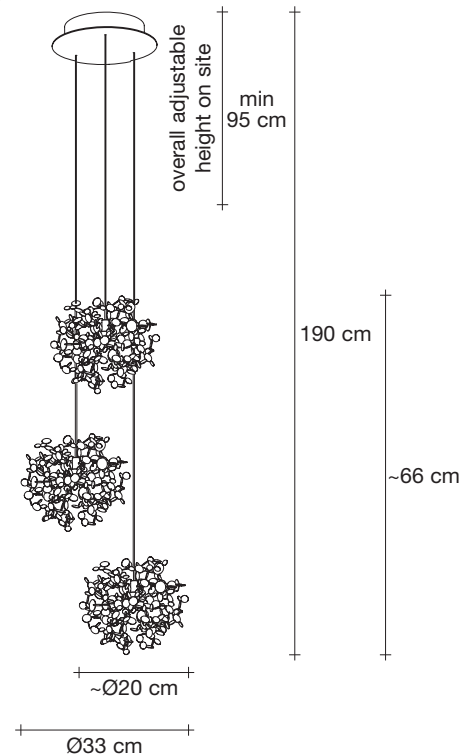

When our Argent collection debuted a decade ago, we knew we had created something special. Working with designer Dodo Arslan, our melding of Italian craftsmanship with contemporary design redefined the industry. Ten years later, we are building upon the success of this original collection with a new chapter: Argent, Mon Bijou.

Again, partnering with Dodo Arslan, we asked ourselves: what have we learned from our evolution as designers and craftsmen? How can we make this new collection as daring, beautiful, and innovative as its predecessor? Our answer is a new series of pendant lights and table lamps that draw inspiration from across design: from the fashion of Paco Rabanne, the work of Verner Panton, the mirrored art of Julio Le Parc, and the natural beauty of the Italian seaside. The result is a lamp reminiscent of a shimmering cloud casting brilliant, ethereal light across the room. Handmade by our craftsmen in stainless steel, each piece is both unique and a modular element of an extremely flexible system. Our goal is to give architects and designers the freedom to express their visions without limits, adapt to any environment, and add a touch of magic. Design Dodo Arslan.

Light source

220-240V ~ 50/60Hz

-  Built in replaceable led module
3 x 1,5W 522 lm 3000K
or optional 3 x 1,5W 492 lm 2700K

dimnable options

-  IGBT
TRIAC

Disc | white

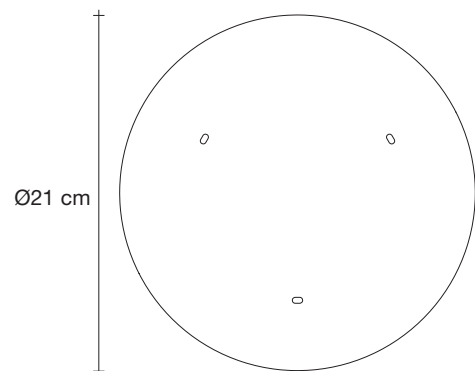

Argent, mon bijou.

design Dodo Arslan
terzani.com

TERZANI



Name





Argent, mon bijou
5 light pendant

Material

stainless steel



Finishes | Code

-  stainless steel
OS05S E8 H9 T
-  gold
OS05S E8 P7 T
-  sunset rose
OS05S E8 A8 T
-  champagne
OS05S E8 Q1 T

Body

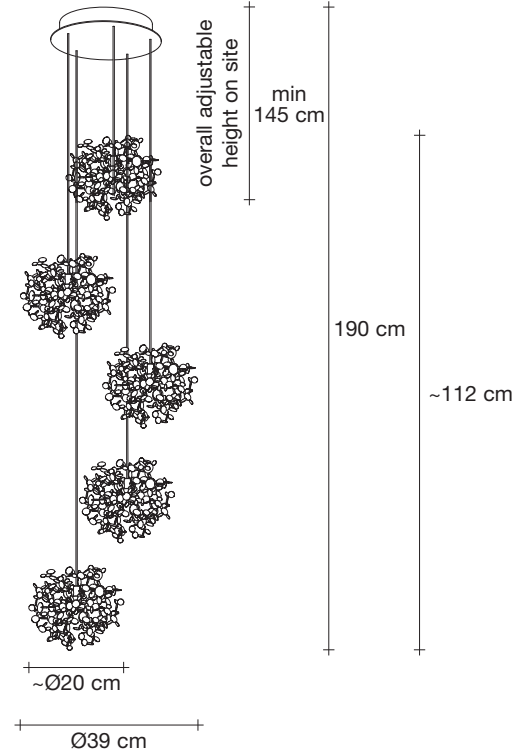

When our Argent collection debuted a decade ago, we knew we had created something special. Working with designer Dodo Arslan, our melding of Italian craftsmanship with contemporary design redefined the industry. Ten years later, we are building upon the success of this original collection with a new chapter: Argent, Mon Bijou.

Again, partnering with Dodo Arslan, we asked ourselves: what have we learned from our evolution as designers and craftsmen? How can we make this new collection as daring, beautiful, and innovative as its predecessor? Our answer is a new series of pendant lights and table lamps that draw inspiration from across design: from the fashion of Paco Rabanne, the work of Verner Panton, the mirrored art of Julio Le Parc, and the natural beauty of the Italian seaside. The result is a lamp reminiscent of a shimmering cloud casting brilliant, ethereal light across the room. Handmade by our craftsmen in stainless steel, each piece is both unique and a modular element of an extremely flexible system. Our goal is to give architects and designers the freedom to express their visions without limits, adapt to any environment, and add a touch of magic. Design Dodo Arslan.

Light source

220-240V ~ 50/60Hz

-  Built in replaceable led module
5 x 1,5W 870 lm 3000K
or optional 5 x 1,5W 820 lm 2700K

dimnable options

-  IGBT
-  TRIAC

Disc | white

4 cm



Ø26 cm

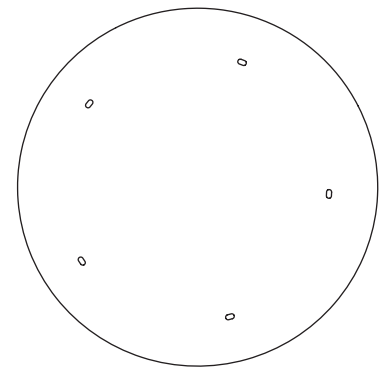

Argent, mon bijou.

design Dodo Arslan
terzani.com

TERZANI



Name





Argent, mon bijou
7 light pendant

Material

stainless steel



Finishes | Code

-  stainless steel
OS07S E8 H9 T
-  gold
OS07S E8 P7 T
-  sunset rose
OS07S E8 A8 T
-  champagne
OS07S E8 Q1 T

Body

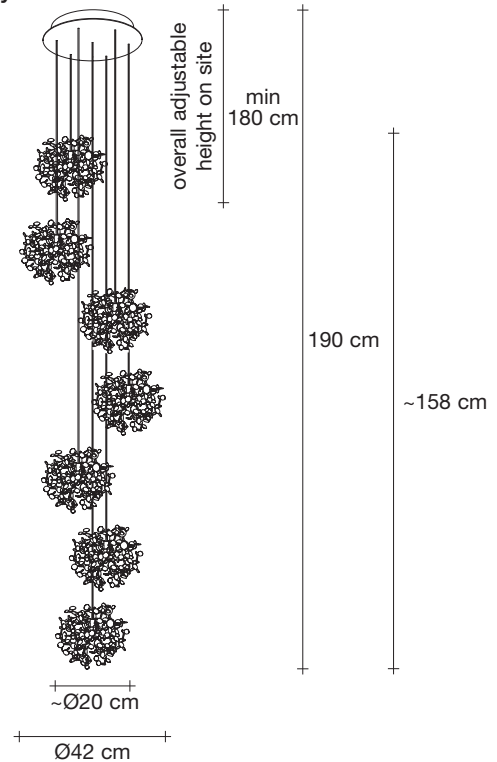



When our Argent collection debuted a decade ago, we knew we had created something special. Working with designer Dodo Arslan, our melding of Italian craftsmanship with contemporary design redefined the industry. Ten years later, we are building upon the success of this original collection with a new chapter: Argent, Mon Bijou.

Again, partnering with Dodo Arslan, we asked ourselves: what have we learned from our evolution as designers and craftsmen? How can we make this new collection as daring, beautiful, and innovative as its predecessor? Our answer is a new series of pendant lights and table lamps that draw inspiration from across design: from the fashion of Paco Rabanne, the work of Verner Panton, the mirrored art of Julio Le Parc, and the natural beauty of the Italian seaside. The result is a lamp reminiscent of a shimmering cloud casting brilliant, ethereal light across the room. Handmade by our craftsmen in stainless steel, each piece is both unique and a modular element of an extremely flexible system. Our goal is to give architects and designers the freedom to express their visions without limits, adapt to any environment, and add a touch of magic. Design Dodo Arslan.

Light source

220-240V ~ 50/60Hz

-  Built in replaceable led module
7 x 1,5W 1218 lm 3000K
or optional 7 x 1,5W 1148 lm 2700K
- dimnable options**
-  IGBT
TRIAC

Disc | white

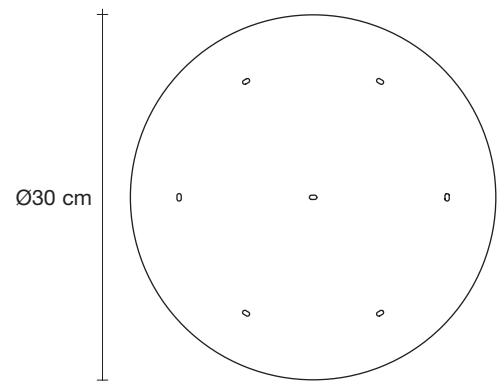

Argent, mon bijou.

design Dodo Arslan
terzani.com

TERZANI



Name

Argent, mon bijou
portable table lamp

Material

stainless steel



Finishes | Code

-  stainless steel
0N88B E7 C8 H
-  gold
0N88B P7 C8 H
-  sunset rose
0N88B A8 C8 H
-  champagne
0N88B Q1 C8 H

Body

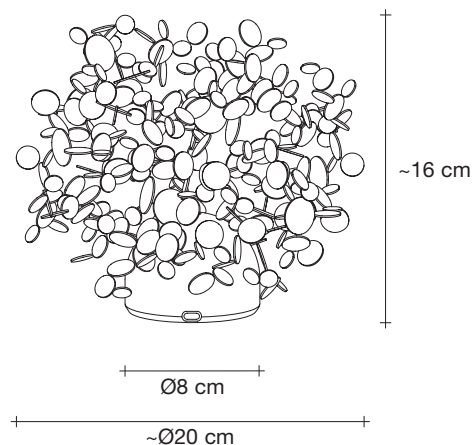

When our Argent collection debuted a decade ago, we knew we had created something special. Working with designer Dodo Arslan, our melding of Italian craftsmanship with contemporary design redefined the industry. Ten years later, we are building upon the success of this original collection with a new chapter: Argent, Mon Bijou.

Again, partnering with Dodo Arslan, we asked ourselves: what have we learned from our evolution as designers and craftsmen? How can we make this new collection as daring, beautiful, and innovative as its predecessor? Our answer is a new series of pendant lights and table lamps that draw inspiration from across design: from the fashion of Paco Rabanne, the work of Verner Panton, the mirrored art of Julio Le Parc, and the natural beauty of the Italian seaside. The result is a lamp reminiscent of a shimmering cloud casting brilliant, ethereal light across the room. Handmade by our craftsmen in stainless steel, each piece is both unique and a modular element of an extremely flexible system. Our goal is to give architects and designers the freedom to express their visions without limits, adapt to any environment, and add a touch of magic. Design Dodo Arslan.

Light source

-  Built in replaceable led module
1,4W max 210 lm 3000K

dimnable options

-  Integrated 4 steps dimmer |
battery life:
min 5.5h
max 36h

USB-A to USB-C 1 m cable and battery included.
Gift box included.

Top view

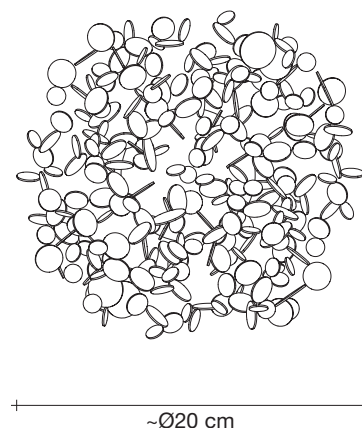

Argent, mon bijou.

design Dodo Arslan
terzani.com

TERZANI

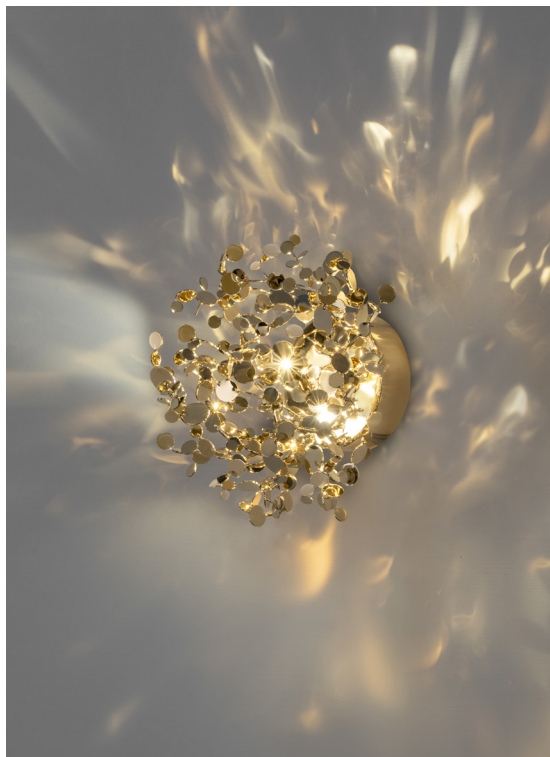

Name

Argent, mon bijou
wall sconce

Material

stainless steel



Finishes | Code

-  stainless steel
OS01A E7 H9
-  gold
OS01A L6 P7
-  sunset rose
OS01A N4 A8
-  champagne
OS01A L6 Q1

Body

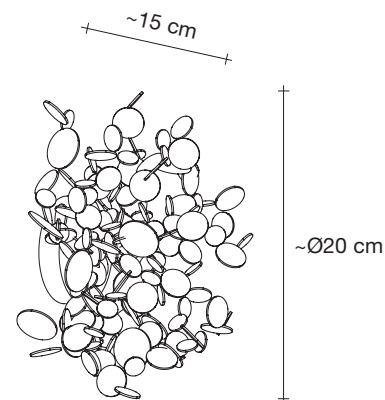

When our Argent collection debuted a decade ago, we knew we had created something special. Working with designer Dodo Arslan, our melding of Italian craftsmanship with contemporary design redefined the industry. Ten years later, we are building upon the success of this original collection with a new chapter: Argent, Mon Bijou.

Again, partnering with Dodo Arslan, we asked ourselves: what have we learned from our evolution as designers and craftsmen? How can we make this new collection as daring, beautiful, and innovative as its predecessor? Our answer is a new series of pendant lights and table lamps that draw inspiration from across design: from the fashion of Paco Rabanne, the work of Verner Panton, the mirrored art of Julio Le Parc, and the natural beauty of the Italian seaside. The result is a lamp reminiscent of a shimmering cloud casting brilliant, ethereal light across the room. Handmade by our craftsmen in stainless steel, each piece is both unique and a modular element of an extremely flexible system. Our goal is to give architects and designers the freedom to express their visions without limits, adapt to any environment, and add a touch of magic. Design Dodo Arslan.

Light source

220-240V ~ 50/60Hz

-  Built in replaceable led module
2,1W 237 lm 3000K

dimnable drivers available

-  0/1-10V
PUSH