

# Harpe, the sound of *light*

design Christian Lava  
terzani.com

**TERZANI**  
LA LUCE PENSATA



**Name**  
Harpe  
3 light pendant

**Materials**  
metal

### Finishes | Code

-  matte nickel  
OW037S E8 B5 T
-  matte black nickel  
OW037S E8 B6 T

### Body

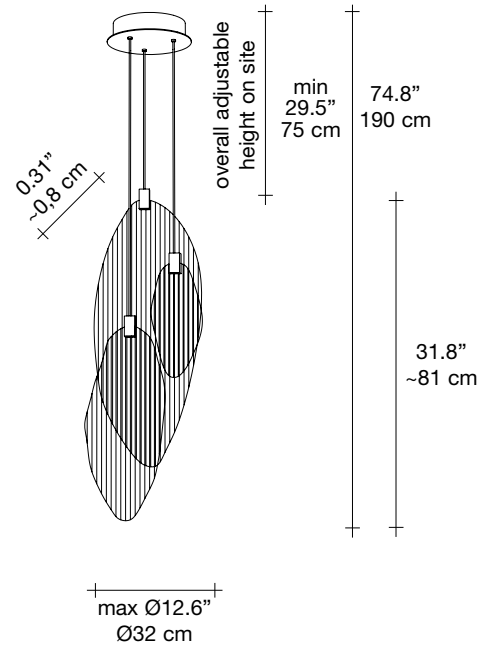

The new Harpe collection comes from the childhood memory of its designer, Christian Lava. Like most children, he would look up into the sky and visualize shapes in the clouds as they passed along. His active imagination would run wild with the fantastic things that would emerge.

One day, Christian looked up into the sky only to see a grey, leaden blanket of clouds. However, against this blank canvas, a break in the sky appeared and bright sunlight came streaming down in rays reminiscent of a harp. It's the memory of this divine instrument that inspired our latest pendant, Harpe.

Made of metal, Harpe is available in three different shapes and sizes and can be assembled in infinite combinations. Design Christian Lava. Made in Italy.

### Light source

700mA

-  Integrated LED  
3 x 2,1W 711 lm 3000K

dimnable drivers available

-  IGBT / TRIAC

### Canopy | white

