

TERZANI

Harpe pendant light

0W013S-FT

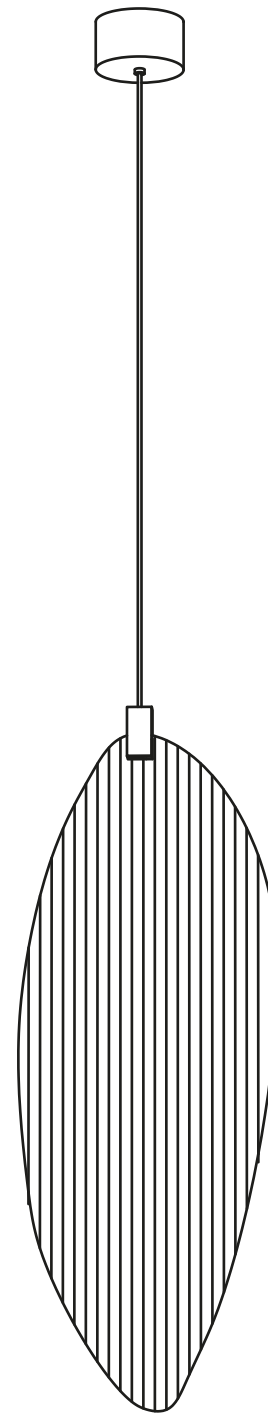

Design Christian Lava

TERZANI

HARPE

CODE 0W013S -- FT
3000K

220-240V ~ 50/60Hz MAX 2,1W

700mA 1xMAX 2,1W

integrated LED

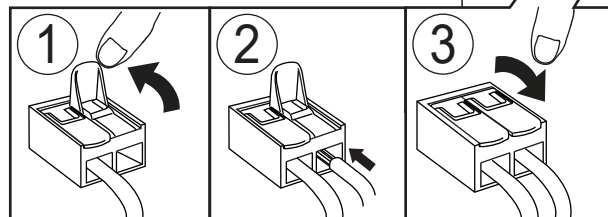
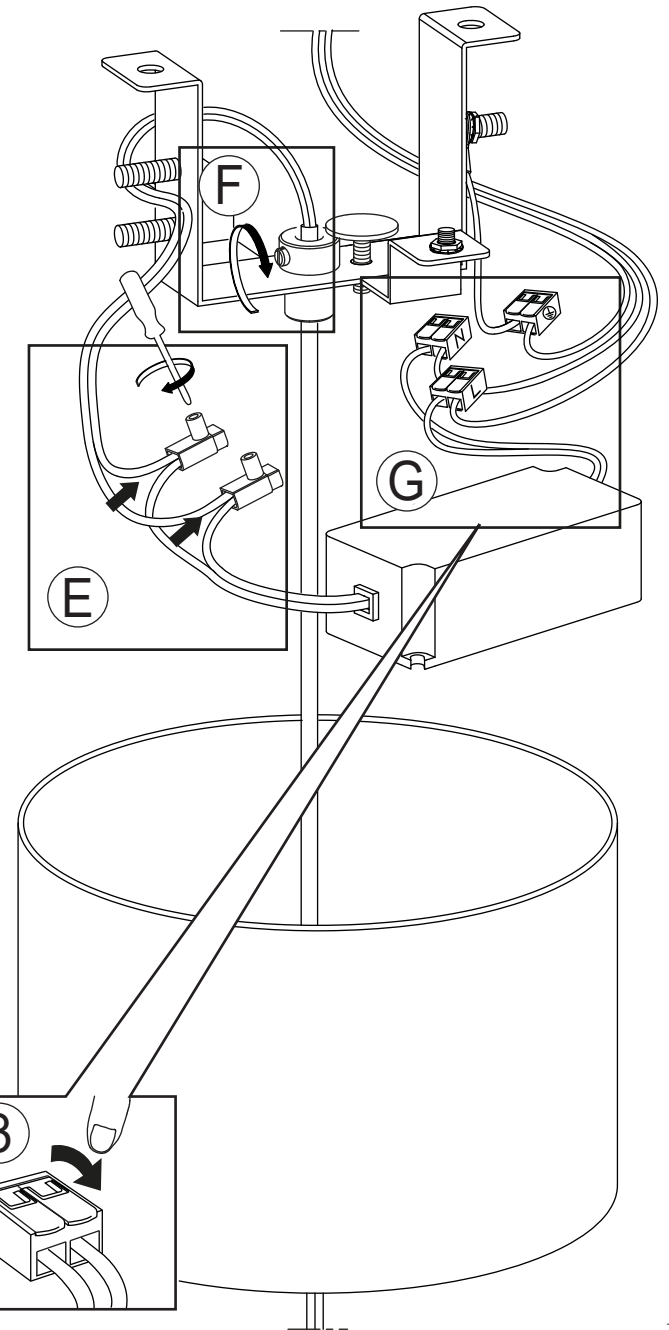
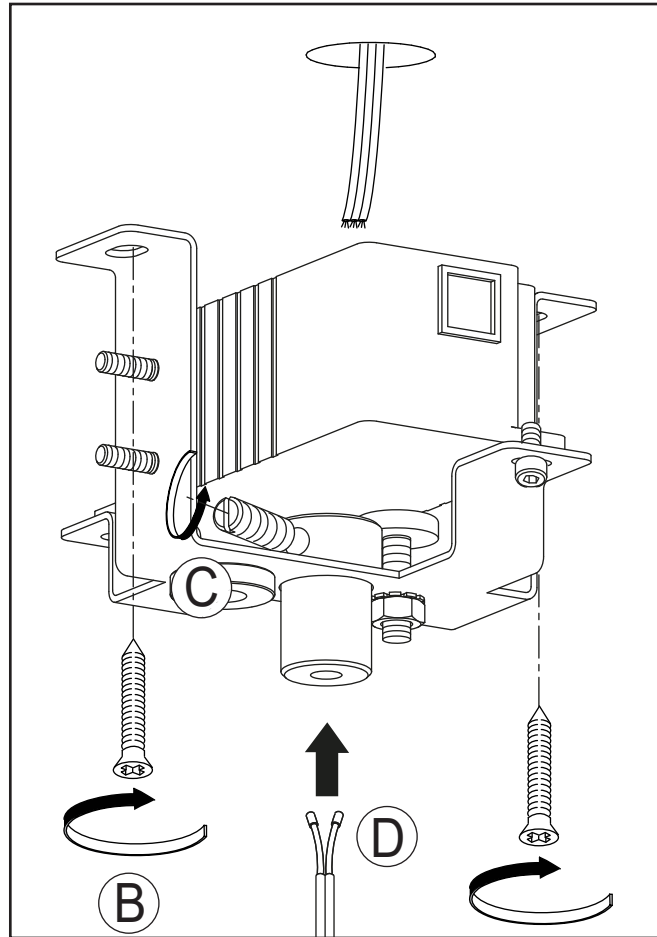
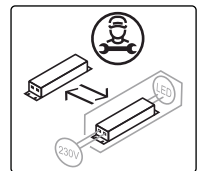
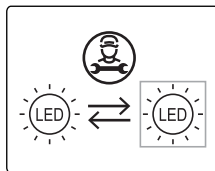

TERZANI

HARPE

CODE 0W013S -- FT
3000K

220-240V ~ 50/60Hz MAX 2,1W

700mA 1xMAX 2,1W

integrated LED



x 1,1m



30000h

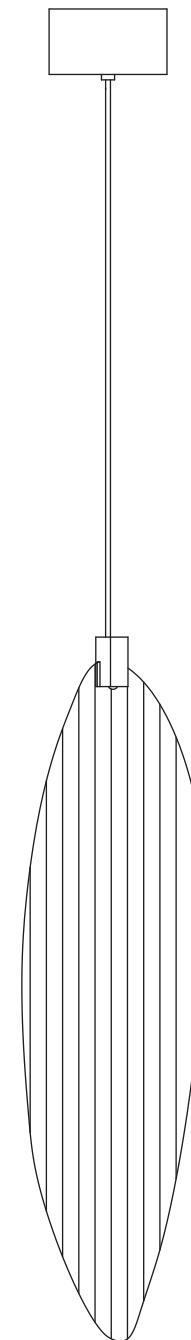
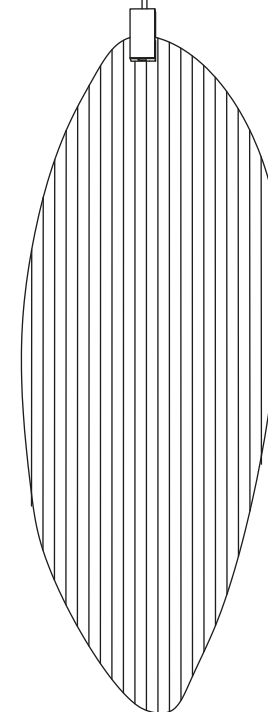
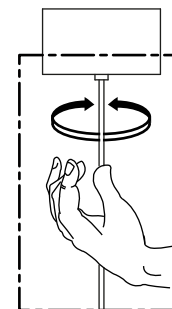
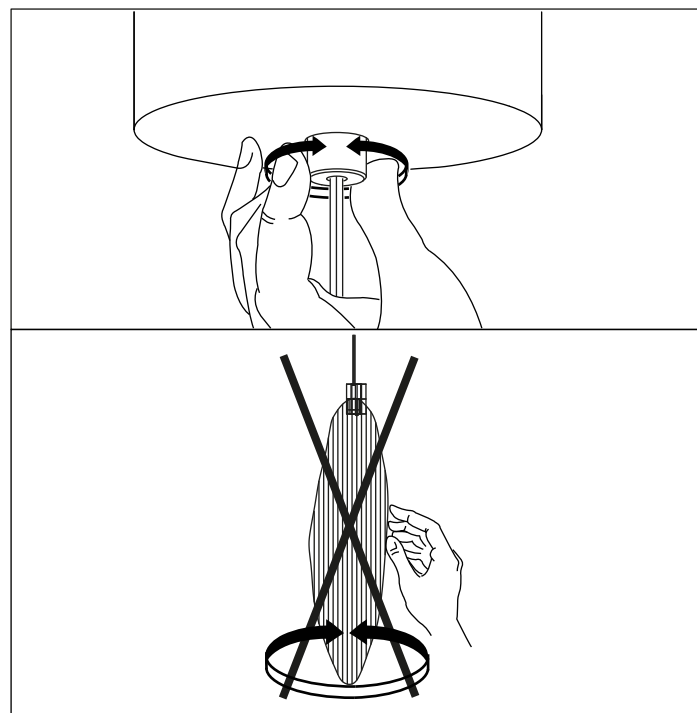
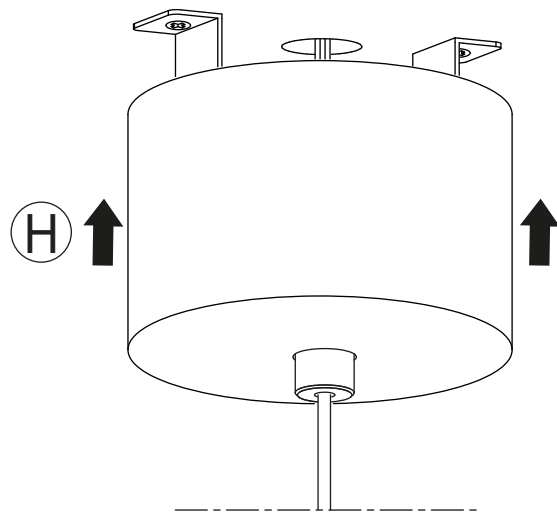
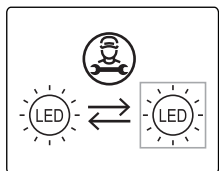
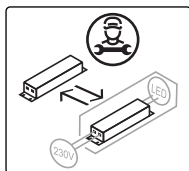

CLEANING INSTRUCTIONS

YES

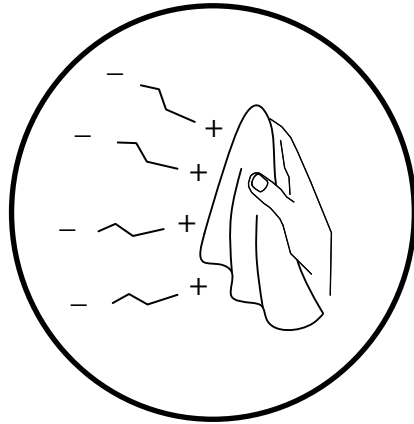

IT Usare panno elettrostatico asciutto

UK Use dry electrostatic cloth

FR Utiliser un chiffon électrostatique sec

DE Verwenden sie ein trockenes elektrostattuch

PY Использовать сухую электростатическую ткань

عربي استخدم قطعة قماش جافة كهرباء

NO

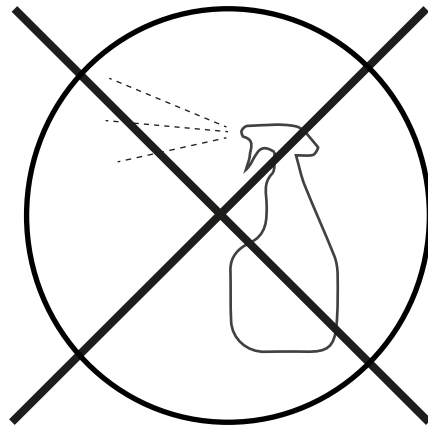

IT Non usare prodotti chimici

UK Do not use chemical products

FR Ne pas utiliser des produits chimiques

DE Verwenden Sie keine Chemikalien

PY Нельзя использовать химикаты

عربي لا تستخدم المنتجات الكيماوية



IT Conservare questa istruzione per la manutenzione | **UK** Keep these instructions for maintenance

FR Garder ces instructions pour l'entretien | **DE** Dies Wartungsanleitung ist aufzubewahren

PY Сохраните эту инструкцию по эксплуатации | عربي احتفظ بهذه الإرشادات للصيانة